

Optimally Controlled Flexible Fuel Vehicle

Robert Bosch LLC, Gasoline Systems
38000 Hills Tech Dr., Farmington Hills, MI 48331, United States

Li Jiang
Li.Jiang@us.bosch.com
+1 (248) 876-1446

Hakan Yilmaz
Hakan.Yilmaz@us.bosch.com
+1 (248) 876-2353

Ricardo Inc., Powertrain Development
40000 Ricardo Dr., Van Buren Township, MI 48111, United States

Mark Christie
Mark.Christie@ricardo.com
+1 (734) 394-3874

University of Michigan, Lay Auto Lab
1231 Beal Avenue, Ann Arbor, MI 48109, United States

Kyung-ho Ahn
akyungho@umich.edu
+1 (734) 936-0424

Anna Stefanopoulou
annastef@umich.edu
+1 (734) 615-8461

Introduction

Although fossil fuels (gasoline and diesel) remain the dominant energy source for internal combustion engines, there have been significant efforts into development of a powertrain system that can be powered with alternative fuels. Ethanol, known for its potentially neutral CO₂ cycle, has been recognized as a promising renewable fuel that can serve as a substitute for conventional gasoline. In fact, current fuel standards in United States (e.g. ASTM D4814) have already allowed up to 10% ethanol for regular gasoline and the use of E85 (85% ethanol and 15% gasoline in volume).

Although today's flex-fuel vehicles are capable of running on gasoline-ethanol fuels, their powertrain and engine management systems are not designed to fully exploit the potential benefits from such fuel flexibility. Instead, the main goal of the current control calibration for flex-fuel vehicles is to improve the cold start performance [1]. Problems associated with cold start are caused by the lower vapor pressure and the lower combustion heating values of ethanol that leads to requirements for a higher fuel injection quantity. Apart from the cold start problems, the lower combustion heating value of ethanol fuels results in higher fuel consumptions (miles/gallon). However, as listed in Table 1, ethanol fuels also possess some advantageous properties. For instance, the higher octane number and latent heat of vaporization of ethanol fuels could lead to higher knock resistance and stronger charge cooling effects. With properly designed engine management system that can exploit these advantageous properties, the use of ethanol fuels in combination with the current development of turbocharged downsizing, direct injection, and variable valve timing can improve the vehicle performance and mitigate the fuel consumption penalties associated with high ethanol content fuels [2, 3].

Table 1: Properties of gasoline and ethanol

Property	Unit	Gasoline	Ethanol
Research Octane Number (RON)	-	92	111
Density	kg/m ³	747	789
Heat of combustion	MJ/kg	42.4	26.8
Stoichiometric air-to-fuel ratio	-	14.6	9.0
Latent heat of vaporization	kJ/kg	420	845
Boiling point	°C	20-300	78.5
Dielectric constant	-	2.0	24.3

The primary objective of this study is to develop an optimized Flex-Fuel Vehicle (FFV), targeting substantial fuel economy improvement with minimum driveability and fuel consumption penalties using a direct injection turbocharged spark ignition engine. Without significant hardware modifications from a gasoline-optimized production engine, the proposed approach employs adaptive engine control strategies combined with a novel ethanol content estimation scheme in order to optimize engine performance for any fuel blend ranging from E0 up to E85.

In order to capture the combustion characteristics of ethanol fuels and their impacts on the optimum control parameter settings, data from the target engine running on fuel blends E0, E24, E55 and E85 were collected during dynamometer testing and analyzed following the design-of-experiment (DoE) method. Then, engine simulation models were developed using these experimental data to explore potential engine performance benefits of different engine configurations, thus allowing engine optimization studies. The testing was carried out on a 2.0L four-cylinder direct injection turbocharged spark ignition engine with its specifications listed in Table 2. Intake and exhaust valve timings could be varied independently to provide valve overlap periods from negative values, when EVC occurs before IVO, to positive values up to 104CA°. All tests on the engine were carried out under fully warm, steady-state operating conditions that covered possible settings of intake valve open, exhaust valve close, spark advance, injection angle, and fuel rail pressure over a wide operation range. Kistler 6125B pressure transducers were flush-mounted in each cylinder, from which cylinder pressure measurements were collected using the RedLine Combustion Analysis System (CAS). Engine-out emissions and filter smoke were recorded using a Horiba MEXA 7100 DEGR emission bench and an AVL415 smoke meter, respectively. In addition, a Siemens ethanol sensor was installed to measure the fuel ethanol content.

Table 2: Specification of the test engine

Variable	Unit	Values/Description
Test engine configuration		In-line four cylinder
Bore	mm	86
Stroke	mm	86
Compression ratio		9.25:1
Displacement	dm ³	1998
Camshaft layout		DOHC – double overhead camshaft, 4-valve, variable valve timing
Boosting system		Twin scroll turbocharger
Maximum power	kW	190 at 5800 RPM
Maximum torque	N·m	353 at 2000-5000 RPM

Engine Performance

The DoE study results in [4] has shown that a more sophisticated calibration scheme that covers the intake/exhaust valve timing and the fuel rail pressure, in addition to the fuel injection and spark timing, can improve the fuel economy of a flex-fuel engine by 2-3%. Experiments have also been conducted to investigate and compare the wide-open-throttle performance of the tested engine when it was operated on fuels E0, E24, E55, and E85 achieving the same torque curve. As illustrated in Figure 1, the stronger charge cooling effects of ethanol fuels reduce the exhaust temperature and thus allow stoichiometric combustion over a wider range of engine speeds, which mitigates the fuel consumption penalties of ethanol fuels.

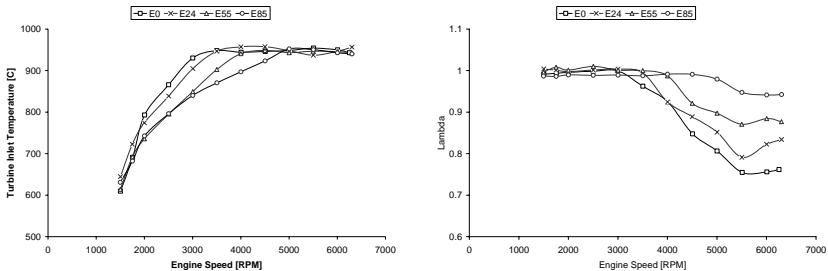

Figure 1: Turbine inlet temperature and lambda measurements when the tested engine was operated on fuel blends E0, E24, E55 and E85 to achieve the same WOT torque curve

In order to exploit the potential benefits of ethanol's higher knock resistance, a simulation model was developed in WAVE to evaluate the performance of an engine with an increased compression ratio and a higher tolerable maximum cylinder pressure. In addition, the WAVE model is used to predict the engine knocking behavior with different variable valvetrain timings and engine compression ratios. As shown in the left plot of Figure 2, with a higher maximum cylinder pressure of 150bar, the engine is predicted to be able to achieve a maximum torque of 500N·m over 2500-4000RPM when running on E85. Despite the benefits exploited from fuels with high ethanol content, the performance of an engine with a higher compression ratio will, in the mean time, suffer from more severe knocking when running on gasoline. In this study, late intake valve closing strategy, as a result of modified intake cam profile and increase phaser authority, is employed to reduce the effective compression ratio to mitigate problems associated with knocking. The simulations shown in the right plot of Figure 2 compare the effects of two intake cam profiles, with an extended duration

of 20CA° and 40CA°, on the torque output of an engine with an increased compression ratio when it is run on E0.

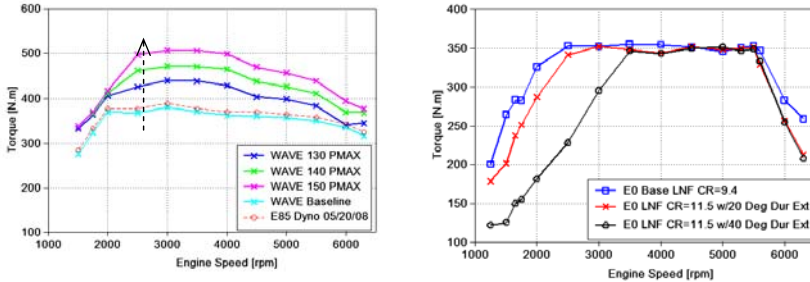

Figure 2: Predicted output torque from an engine, running on E85, (a) Left: with higher maximum cylinder pressures (120 to 150bar in the arrow direction); (b) Right: with a higher compression ratio and two different intake cam profiles

Engine Optimization

In this section, several necessary hardware modifications of the engine component design and fuel system specification will be discussed. These modifications were made to improve the engine performance with high ethanol content fuels without penalizing its performance with gasoline.

Engine Design

According to engine optimization investigation conducted based on the 1-D simulation model, the compression ratio and the maximum cylinder pressure of the optimized flex-fuel engine are determined to be 11.3:1 and 140bar, respectively. In order to achieve the desired compression ratio, the piston bowl design was modified, as illustrated in Figure 3. Such design also takes into consideration of the change of valve movements, resulted from the change of cam profile and phaser authority for the late intake valve closing strategy, and the change of injection spray targeting for better emissions. In addition, engine components with higher strength, such as the cylinder block and cylinder head, are used to withstand a higher maximum cylinder pressure.

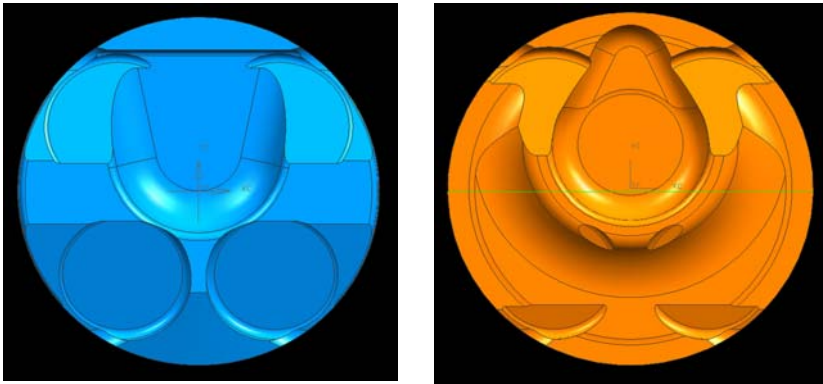

Figure 3: Piston bowl designs (left: optimized engine, right: tested engine)

Fuel System Specification

As listed in Table 3, the operation pressure of the direct fuel injection system in the tested engine is 150bar, while the one planned for the optimized flex-fuel engine is targeted to be 200bar. The high-pressure fuel path in the tested engine includes a 3-lob cam driven fuel pump with a nominal flow rate of 0.9cc/rev, a fuel rail with a volume of 135cc and an operation pressure up to 150bar, a pressure sensor with a measurable range of 0-200bar, and injectors with a nominal flow rate of 22.5cc/s at 100bar.

Table 3: Specifications of fuel system components

Components	Tested Engine	Optimized Engine
Fuel Pump	3-lob cam driven, 0.9cc/rev	4-lob cam driven, 1.1cc/rev
Injector	22.5cc/s	22.5cc/s, optimized spray targeting
Fuel Rail	135cc, 150bar	66cc, 200bar
Pressure Sensor	200bar	260bar

To accommodate the requirements of a higher injection quantity with ethanol fuels, a 4-lob cam driven fuel pump with a nominal flow rate of 1.1cc/rev is used to maintain a higher fuel rail pressure. Associated with this change, the operation pressure of the fuel rail is increased up to 200bar, and the measurable range of the pressure sensor is extended to 0-260bar. In addition, the volume to the fuel rail is de-

creased to 66cc to shorten the start time and reduce pulsation during catalyst heating and idle operations. Based on results from the on-going testing, injectors equipped in the tested engine are adequate for the flex-fuel applications.

As addressed in [8], a novel strategy for SULEV emission requirements were developed after the completion of the advanced system engineering project between Bosch and Ricardo on DI Boost. The proposed strategy will be implemented in this project to achieve ULEV emissions for ethanol fuels up to E85 and investigate the potentials for SULEV standards. The proposed methodology includes the implementation of a multi-injection strategy in Figure 5, modification of the piston bowl design and exhaust system layout, and spray targeting optimization in Figure 4.

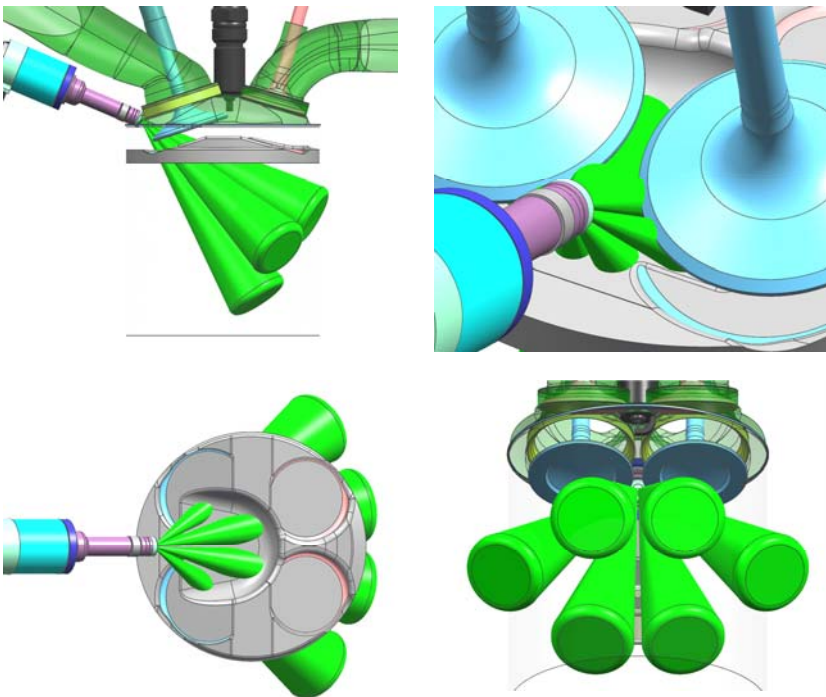

Figure 4: Optimized injection spray targeting for better emissions

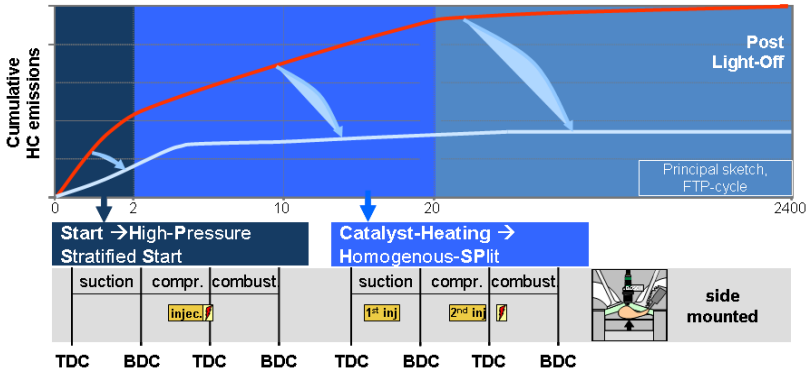

Figure 5: Injection strategy for emission reduction [8]

Engine Management System (EMS) Development

The engine system can be divided into air, fuel and ignition subsystems. Accordingly, the engine management system is developed, as illustrated in Figure 6, to control the throttle angle, intake/exhaust valve timings, and wastegate in the air subsystem; the fuel rail pressure and injection duration in the fuel subsystem; and the spark timing in the ignition subsystem.

Given a pedal command, the calibrated engine torque structure interprets the torque demand from the driver and determines the desired engine torque, $(T)^*$, by coordinating it with other internal and external torque demands. Depending on the desired engine torque, $(T)^*$, and engine speed, N , the engine control unit first determines the various operating set-point demands, among which the set-points for spark timing, $(\phi_s)^*$, injection timing, $(\phi_{inj})^*$, fuel rail pressure, $(p_r)^*$, and variable camshaft positions, $(\phi_{VVT})^*$ are identified using the DoE method. These operating set-points demands are then taken as input to the subsystem controllers as feedforward control commands. As the fuel properties vary with the ethanol content, these operating set-point commands should be adjusted accordingly in order to optimize the overall performance of a flex-fuel engine.

Using the current map-based control scheme, such control parameter optimization will require much more calibration efforts for a flex-fuel engine. Depending on the number of fuel blends selected for calibration, the development cost could dramatically increase, which in turn determines the engine performance since the engine

control parameters are interpolated between these calibrated values. Therefore, this study investigates the feasibility and performance of model-based feedforward controllers for some of the key parameters and cylinder-individual combustion control of spark advance using cylinder pressure feedback.

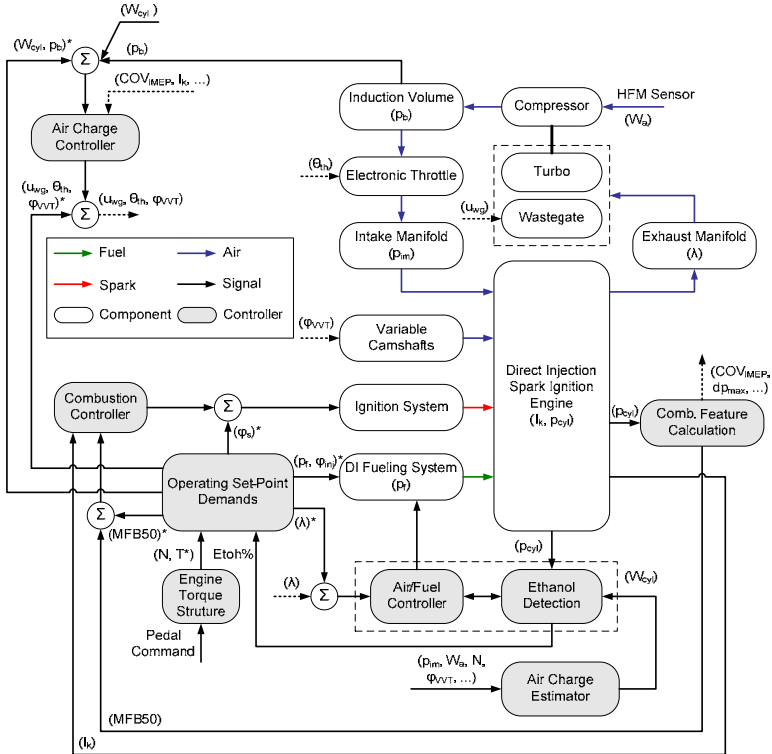

Figure 6: Block diagram illustrating the control concepts in the engine management system

Combustion Control

Spark advance, one of the key parameters for engine performance, is normally controlled in an open-loop manner using the map values stored in the ECU as a function of engine speed and load. However, these values determined during the calibration process are not able to take into consideration all the influencing factors such as air

humidity, engine wear, and fuel properties [14]. In order to achieve a cost-effective calibration process for optimal spark advance, many approaches have been proposed in literature for spark advance control using cylinder pressure feedback. Most of the approaches employ a combustion phase indicator, derived from cylinder pressures on a cycle-to-cycle basis. As reviewed in [15], the most commonly used combustion phase indicators include the location of peak pressure (LPP), the location of 50% mass fraction burned (MFB50), the location of maximum pressure rise, the location of maximum pressure rise, and the value of relative pressure ratio 10 CA° aTDC. In this study, MFB50 is selected as the combustion phase indicator for maximum brake torque timing due to its comparatively lower sensitivity to cycle-by-cycle combustion variations and weaker dependence of engine speed and load [15].

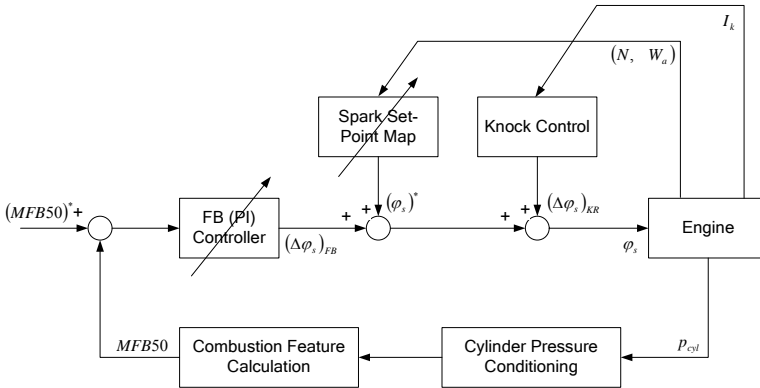

Figure 7: Block diagram illustrating the control concepts in combustion controls

Figure 7 illustrates the proposed cylinder-individual combustion control of the spark timing using cylinder pressure feedback. The conventional map stores the spark timing set-points as a function of engine speed and loading conditions. The knock control is activated once knocking is detected using the knock sensor and then adjusts the spark timings depending on the knock intensity and the fuel ethanol content. Such feedforward control scheme is first improved by adding cylinder-individual adaptive feedback PI controllers in terms of MFB50. Due to the presence of measurement noise and cycle-to-cycle combustion variation, the cylinder pressure measurements are first conditioned and then MFB50 values are computed. To improve the transient response of the controller, the stored set-point values of spark timing are then adapted online based on the engine average spark advance adjustment commanded from these cylinder-individual PI controllers.

Ethanol Detection

In order to enable adaptive engine controls for performance optimization and emissions reduction over various ethanol fuels, it is crucial to know the ethanol concentration of the fuel in order to enable adaptive engine controls. Utilizing the different dielectric constant between gasoline and ethanol, as listed in Table 1, capacitance-based sensors can be installed in fuel line to measure the ethanol content. Despite its desirable accuracy, the use of an ethanol sensor increases the system cost and system complexity, which motivates the development of virtual ethanol sensor using existing sensor to calculate indicative features. One popular method is developed using exhaust gas oxygen (EGO) sensor to calculate, given the amount of air charge and injected fuel, the stoichiometric air-to-fuel ratio (SAFR), and thus estimate the ethanol content. However, since such detection feature is directly computed from the amount of the estimated air charge and injected fuel, the associated ethanol content estimation has a high sensitivity to the intake mass air flow (MAF) sensor bias and fuel injector drift [10, 11]. In [12], a method was proposed to estimate the ethanol content, with the presence of MAF sensor drifts, by integrating the measurements from EGO and manifold absolute pressure (MAP) sensors.

Among other methods, approaches are developed using cylinder pressure measurements to extract features that can indicate the heat of combustion (HC) [13], and the latent heat of vaporization (LHV) [6]. As discussed in [7], detection features associated with SAFR and HC are redundant with respect to the amount of injected fuel, while that associated with LHV has a relatively lower sensitivity. Inspired from such analytical results, a method that extracts LHV based detection feature from cylinder pressure measurements is proposed in this study to address and compensate the effects of injector drifts on ethanol content estimation.

In a direct injection engine, after the fuel is injected into the combustion chamber when the intake and exhaust valves are closed, the liquid fuel absorbs heat from the cylinder charge during vaporization, thus cooling the charge and influencing the evolution of cylinder pressures. In order to extract such charge cooling effects, a unique injection mode that switches between the single and split injection for a specific cylinder is introduced. During the single injection (Si), all the demanded fuel is injected during the intake stroke when the influences of the charge cooling effects on the cylinder pressure are compensated with additional air charge. During the split injection (Sp), a fraction of the fuel is injected during the intake stroke, while the rest is injected during the compression stroke after the intake valve is closed. A detection feature, *residue*, is then introduced in [6] to capture the difference in cylinder pressure evolution during single and double injection.

As illustrated in Figure 8, there exists a significant difference between the evolution of the *residue*, extracted from dynamometer measurements, when the engine was operated with E0 and E85 under the same steady-state engine operation conditions (stoichiometric combustion at the commanded engine speed and load). The higher *residue* values associated with E85, in fact, indicate the stronger charge cooling effects due to its higher latent heat of vaporization and the higher fuel injection quantity. The correlation between the detection feature, *residue*, and the fuel property, latent heat of vaporization, encourages further investigation of its feasibility to construct a virtual sensor for ethanol content.

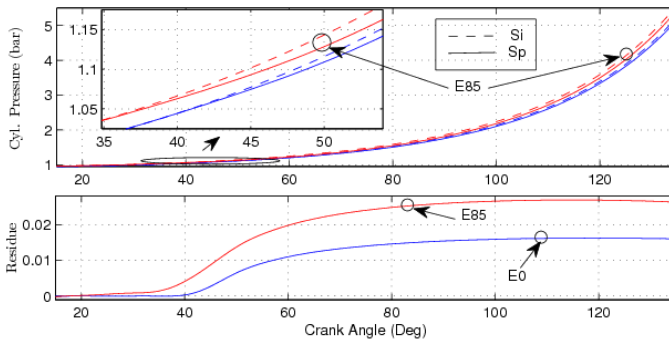

Figure 8: Cylinder pressure and residue evolution during the compression stroke at the engine speed of 2500RPM and intake mass air flow rate of 170kg/hr

Although monotonic correlations between the detection feature, *residue*, and the ethanol content are not observed over the entire operation region during the dynamometer testing, they have been observed at specific operation conditions. With the bi-affine data-driven model introduced in [7], such correlation can be well captured at certain operation points. For example, as shown in the left plot of Figure 9, the bi-affine model is able to capture such correlation under various loading conditions at the engine speed of 2500RPM. Based on the parameterized bi-affine model, the ethanol detection accuracy, at the engine speed of 2500RPM and intake mass air flow rate of 130kg/hr, of the SAFR, HC, and LHV based detection features during fault-free conditions ($f_{ef} = 0$), 5%, and 10% fuel injector drifts ($f_{ef} = 0.05, 0.1$) are compared in the right plot of Figure 9. The SAFR and HC based detection features clearly demonstrate similar trends under fuel injector drifts, which validates the sensitivity analysis conclusion in [7] derived from their fundamental physical properties. It can also be observed that the LHV based detection feature provides an independent indication of ethanol content that is relatively less sensitive to the injector drifts.

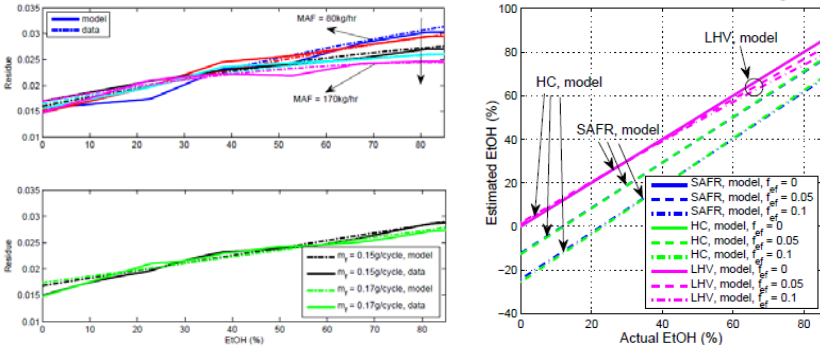

Figure 9: Left: experimental and modelled detection feature, *residue*, under various loading conditions (80kg/hr to 170kg/hr in the arrow direction) at 2500RPM; Right: predicted behaviour of detection features under fault-free, 5% and 10% fuel injection drifts at 2500RPM, 130kg/hr

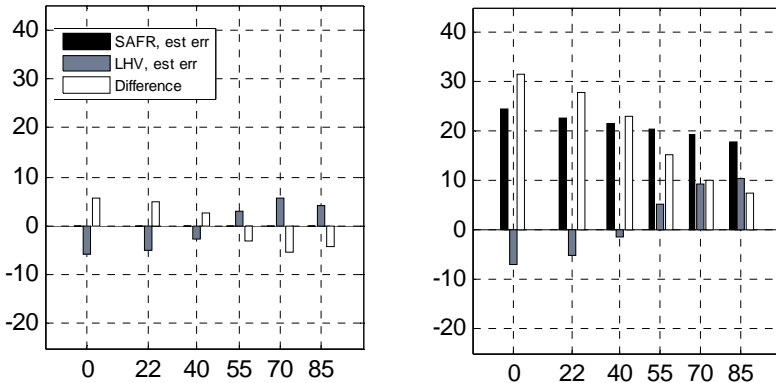

Figure 10: Ethanol content estimation errors using SAFR and LHV features under (a) Left: fault-free condition; and (b) Right: 10% fuel injector drift

Figure 10 shows the ethanol detection errors using the SAFR and LHV based detection features during fault-free conditions and 10% fuel injector drifts. At the illustrated operation condition, although the LHV detection feature leads to an ethanol content estimation error of less than 5 ethanol volumetric percentage (etohV%), it achieves better estimation accuracy over the entire ethanol fuel range during 10% fuel

injector drifts, which suggests the potentials of integrating both features to improve ethanol content estimation accuracy and robustness.

Conclusions

With minimum hardware modifications from a gasoline-optimized commercial engine, the current study aims to develop a true flex-fuel vehicle system using a novel engine management system to achieve optimal performance over ethanol fuels ranging from E0 up to E85. Based on the results from engine optimization studies, the flex-fuel optimized engine is designed with a higher compression ratio and an increased maximum tolerable cylinder pressure in order to exploit the benefits of high knock resistance of ethanol fuels. In the mean time, in order to mitigate the gasoline performance deterioration caused by such modifications, advanced variable valvetrain strategies such as late intake valve closing are employed. Procurement of the modified engine components is completed and one prototype engine has been built for dynamometer testing and engine parameterization.

Apart from these engine hardware modifications, cylinder-individual control of the spark timing using cylinder pressure feedback is developed to achieve maximum brake torque output, which could reduce the calibration efforts for compensating the influences of the varying fuel properties. To enable adaptive engine controls, various ethanol detection methods have been investigated. In this study, a method is proposed to extract the detection feature associated with the latent heat of vaporization from cylinder pressure measurements, based on which ethanol content can be indicated. On-going efforts are being made to develop a comprehensive ethanol detection strategy that could provide fault tolerant ethanol estimation by integrating the detection feature associated with the latent heat of vaporization with that associated with the stoichiometric air-to-fuel ratio via the exhaust oxygen sensor. After the completion of base engine parameterization, the proposed engine management system strategies will be implemented and evaluated.

References

1. A. Stodart, J. Maher, L. Greger, and J. Carlsson, "Fuel System Development to Improve Cold Start Performance of a Flexible Fuel Vehicle", *1998 SAE World congress*, 982532
2. P.E. Kapus, A. Fuerhapter, H. Fuchs, G. K. Fraidl, "Ethanol Direct Injection on Turbocharged SI Engines – Potential and Challenges", *2007 SAE World congress*, 2007-01-1408

3. D. Woldring, T. Landenfeld, M.J. Christie, "DI Boost: Application of a High Performance Gasoline Direct Injection Concept", *2007 SAE World congress*, 2007-01-1410
4. M.J. Christie, N. Fortino, H. Yilmaz, "Parameter Optimization of a Turbo Charged Direct Injection Flex Fuel SI Engine", *2009 SAE World congress*, 2009-01-0238
5. L. Jiang, J. Vanier, H. Yilmaz, H. Yilmaz, A. Stefanopoulou, "Parameterization and Simulation for a Turbocharged Spark Ignition Direct Injection with Variable Valve Timing", *2009 SAE World congress*, 2009-01-0680
6. N. Oliverio, L. Jiang, H. Yilmaz, A. Stefanopoulou, "Ethanol Detection in Flex-Fuel Direct Injection Engines Using In-Cylinder Pressure Measurements", *2009 SAE World congress*, 2009-01-0657
7. K. Ahn, L. Jiang, H. Yilmaz, A. Stefanopoulou, "Ethanol Content Estimation in Flex Fuel Direct Injection Engines using In-Cylinder Pressure Measurements", *to be published in 2010 SAE World congress*, 2010-01-0166
8. A. Brdarski, J. Kern, D. Woldring, H. Yilmaz, M.J. Christie, and K. Müller-Haas, "SI engine hardware and software design for high power, low emission applications". *2009 SAE World congress*, 2009-01-0617
9. G.L. Seitz *et al.* "Methods of Determining the Composition of Fuel in a Flexible Fuelled Vehicle with an O₂ Sensor", US Patent 5850824
10. K. Ahn, A.G. Stefanopoulou, and M. Jankovic, "Estimation of Ethanol Content in Flex-Fuel Vehicles using an Exhaust Gas Oxygen Sensor: Model, Tuning and Sensitivity". In *Proceedings of ASME 1st Annual Dynamic Systems and Control Conference*, Ann Arbor, October 2008
11. F. Theunissen, "Percent Ethanol Estimation on Sensorless Multi-Fuel Systems; Advantages and Limitations". *2003 SAE World congress*, 2003-01-3562
12. K. Ahn, A.G. Stefanopoulou, and M. Jankovic, "Tolerant Ethanol Estimation in Flex-Fuel Vehicles during MAF Sensor Drifts". In *Proceedings of ASME 2nd Annual Dynamic Systems and Control Conference*, Hollywood, October 2009
13. S. Washino and S. Ohkubo, "Fuel Properties Detecting Apparatus for an Internal Combustion Engine". US Patent 6041278
14. G.W. Pestana, "Engine Control Methods using Combustion Pressure Feedback", *SAE Paper*, 890758
15. E. Pipitone, "A Comparison between Combustion Phase Indicators for Optimal Spark Timing". *Journal of Engineering for Gas Turbines and Power*, Vol. 130 / 052808, pp 1-11, 2008